

THEORETICAL MODELLING OF ELECTRO-CYCLONE SEPARATOR FOR ARRESTING DIESEL SOOT PARTICULATE MATTER

¹Dr. N.Mukhopadhyay,²Ashim Roy

¹Assistant Professor, Mechanical Engineering, Jalpaiguri Government Engineering College. Jalpaiguri-735102, W.B.,India.

²Superintendent of Workshop, Jalpaiguri Government Engineering College. Jalpaiguri-735102, W.B.,India
ashimbakum_ws@yahoo.com, ashim_roy67@rediffmail.com,

ABSTRACT: Diesel soot particulate matter is considered to be the most harmful pollutant as because the air borne particulate matters are known to constitute a major human risk. Recent epidemiological studies reported that particles with diameters of less than 2.5 micron are most fetal for living beings due to inhaling of the same. The reduction of particulate emissions from diesel engine is one of the most challenging problems in modern society. Diesel particulate emission can easily enter human respiratory system and are capable of causing cancer because of their association with absorbed and condensed potential occupational carcinogenic compounds such as poly-nuclear aromatic hydrocarbon, Nitro-PAH and sulphates. The main particulate fraction of diesel exhaust consists of fine particles. Diesel particulate matters are inhalable and may easily penetrate deep into the lungs because of their small sizes. The rough surfaces of these particles make it easy for them to bind with other toxins in the environment, thus increasing the hazards of particle inhalation.

Several solutions have been proposed to date like ceramic filtration, wire mesh filtration, direct contact type filtration systems etc., which suffer from high engineering complexity, high costs as well as increased backpressure. Most of the proposed solutions deteriorate diesel engine combustion performance and simultaneously increases fuel consumptions.

This paper presents the electrostatic attraction of ultra fine diesel soot particulate matter for exhaust gas treatment and the theoretical modeling of effect of collection efficiency of ultra fine particulate matter emitted from diesel engine exhaust gas through an electro-cyclone and other operating parameters i.e. applied voltage, flow rate, the particle parameters like particle size, shape and dielectric properties, exhaust gas density, viscosity on the performance of electro cyclone separator as a Diesel Soot Particulate Emission Arrester. Improved modified design of a non-contact type filtration system of electro-cyclone separator presents lower back pressure drop with enhanced particulate collection efficiency for reducing ultra fine diesel engine exhaust soot particulate matter emissions. Particulate diameter, exhaust gas density, viscosity presents similar matching trends with the published studies. Graphical trend of applied voltage vs particulate diameter is well justified by the theoretical analysis of the model.

Keywords: Diesel soot particulate, Electro-cyclone Separator, Viscosity, Density, Applied voltage.

INTRODUCTION:- Controlling diesel engine emission is one of the most important aspects of air pollution control management. In the field of transportation diesel engine is widely used for running the vehicle, car, train etc. In the agricultural sector there is also wide application of diesel engine. Undoubtedly diesel engine has higher emission of particulate matter along with Nox, Hydrocarbons, Sox rather than the S.I.Engine. Particle Composition For A Heavy-Duty Diesel Engine Tested in Heavy-Duty Transient Cycle Carbon 41% Ash and Other 13% Sulfate and Water 14% Unburnt Oil 25% Unburnt Fuel 7% [1]. The Diesel soot consist of small solid carbon particle, sulfate, and metal. which are the prime response of air pollution and having the adverse effects of atmosphere particulate concentration. Many systems are currently being considered for the control of emissions of particulate matter by diesel engine. Of these, the most extensively researched are on the cyclone separator and electro-cyclone separator[2]. Many studies of Cyclone separators with cement industries, cotton industries, Gas turbine Combustor applications, process industries and as a two phase flow separators are already available[3-9] in the literatures. Though very few studies are reported[Tilak, 1989 (10);Mukhopadhyay,2006(11)] with Cyclone Separators as a Diesel Engine exhaust after treatment device for controlling soot particulate emission but no such studies have been still reported by using electro-cyclone as diesel engine soot particulate arrester.

Electro-cyclone separator having a two phase, three dimensional, swirling turbulent flow with free outer vortex (irrotational flow) and forced inner vortex (solid body rotation) is a complex flow device combined with induced electric field. Process for diesel soot particulate emission separation using continuous application of induced electric field inside the cyclone wall of electro-cyclone separator, presents a simple construction which produces low back pressure and reasonably high particulate collection efficiencies. Arresting of diesel soot particulate matter emitted from diesel engine exhaust reduces the DPM formation and thus keeps the environment clean. Proposed results are established through theoretical and experimental study.

This paper present the study of the electro-cyclone separator's collection efficiency, cut off diameter equations for diesel soot particulate emission considering outer vortex, inner vortex flow. The solid-gas separation mechanism of electro-cyclones with electrostatic field is a nonlinear problem and is very complex. It is very important to study the mechanism of diesel soot particulate filtration, mainly nano-size particle (range of 0.1 to 1.0 micro meter) through after treatment devices like for cyclone and electro-cyclone separator for design optimal for the effective usage.

The technology of the combination of the cyclone, electrostatic attraction has been applied in exhaust gas treatment . The significant increases of collecting efficiency of electro-cyclone with the help of electrostatic attraction have been demonstrated. The state of the art analysis orientate us to make the choice of two technologies : cyclone plus electrostatic precipitation.

FORMULATION OF THE THEORETICAL MODEL: Cyclones have a number of advantages in air sampling, including their relatively low cost of construction and ease of operation. Since they have no moving parts, their maintenances are very easy. After all, the cyclones samplers have the highest ratio of performance to energy consumption, compared to other sampling technologies. Cyclone performance decreases with particle diameter. It has been demonstrated that particle collection efficiency could be enhanced if electrical forces are applied to supplement the inertial forces. In electro-cyclone, there is an additional force i.e. electric force, apart from the centrifugal force and drag force. The electric force is proportional to the

product of particle charge and the strength of the electrostatic field. The movement of a particle is determined by the balance of the centrifugal force, the drag force and the electric force. The governing forces in an electro-cyclone separator are F_c (Centrifugal force), F_d (Drag force), F_e (Electrostatic force). In the electro-cyclone outer vortex fluid field, there are three forces (centrifugal force F_c electrostatic force F_e and drag force F_D) acting on the particle in the radial direction. The centrifugal force plus electrostatic force are equal to the drag force acting on the particle at the balance point.[11] The force balance differential equation can be setup from Newton's second law. We get the formula of the differential equation for particle motion for solid gas separation in a electro-cyclone.

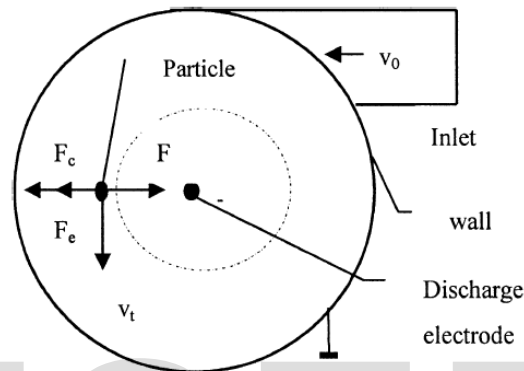

Fig. 1. The forces acting on a particle in an electrocyclone.

The driving forces acting on the particles are centrifugal forces, Electrostatic force and Drag force. [11]

In the electro-cyclone outer vortex fluid field, there are three forces (centrifugal force F_c electrostatic force F_e and drag force F_D) acting on the particle in the radial direction. The centrifugal force plus electrostatic force are equal to the drag force acting on the particle at the balance point. [11]. We get the formula for particle motion of solid gas separation in a electro-cyclone as follows

Centrifugal force + Electrostatic force = Drag Force [12]

$$F_c + F_e = F_d \text{ ----- (i)}$$

Let us consider that the charged induced on the particle is q_{es} due to local electric field of strength E (V/m), then the Electrostatic force acting on a particle can be given as [13]

$$F_e = q_{es} E$$

$$F_e = q_{es} \frac{V}{r} \text{ ----- (ii)}$$

If a particle moves in a circular path in the electro-cyclone separator with radius r and velocity v_t along the path, then the centrifugal force acting on a particle can be calculated as follows:

Centrifugal force

$$F_c = mf_r - mf_c = m(f_r - f_c) = \frac{d_p^3 \pi}{6} \rho_p \left[\frac{d^2 r}{dt^2} - r \left(\frac{d\theta}{dt} \right)^2 \right] \text{ ----- (iii)}$$

$$f_r = \text{Particle radial acceleration} = \frac{d(v_r)}{dt} = \frac{d}{dt} \left(\frac{dr}{dt} \right) = \frac{dr}{dt}$$

$$f_c = \text{Particle angular acceleration} = r \left(\frac{d\theta}{dt} \right)^2$$

$$m = \text{Mass of the particle} = \frac{d_p^3 \pi}{6} \rho_p$$

Where d_p is the soot particulate diameter, ρ_p is the density of soot particulate matter in kg/m^3 , v_r is the angular velocity in m/sec. and r is the radius of the electro-cyclone body.

According to the Barth model, it has been assumed that the particle radial velocity was assumed to be zero because of static status.

$$\text{Hence } V_r = \frac{dr}{dt} = 0 ;$$

$$\Rightarrow \frac{d^2r}{dt^2} = 0;$$

Then the equation (i) becomes

$$F_c = -\frac{d_p^3 \pi}{6} \rho_p \left[r \left(\frac{d\theta}{dt} \right)^2 \right] \text{----- (iv)}$$

Since $r \frac{d\theta}{dt}$ = Particle tangential velocity (the same as air tangential velocity V_t can be determined by the following equations)

$$r \frac{d\theta}{dt} = V_t$$

$$\frac{d\theta}{dt} = \frac{V_t}{r}$$

Research results of Shepherd and Lapple (1939), Ter Linden (1949) and Lieth (1972) indicated that air stream tangential velocity in the annular section (at the same cross-sectional area) of the cyclone could be determined by equation

$$V_t r^n = C$$

Where V_t = Tangential Velocity

r = Air stream radius

n = 0.5 (in outer vortex) – Shepherd and Lapple 1939

C = Constant

For simplicity, it is assumed that V_t equals the average air stream inlet velocity V_{in} when r equals the radius of the cyclone well (R) that is

$$V_t r^{0.5} = V_{in} R^{0.5}$$

$$\therefore V_t = \left(\frac{R}{r}\right)^{0.5} V_{in}$$

Now $\frac{d\theta}{dt} = \frac{V_t}{r} = \frac{1}{r} \left(\frac{R}{r}\right)^{0.5} V_{in}$

Therefore, $\left(\frac{d\theta}{dt}\right)^2 = \frac{R}{r^3} V_{in}^2$

Now the equation (iii) can be written as

$$F_c = -\frac{\pi d_p^3 \rho_p R}{6 r^2} V_{in}^2 \text{------(v)}$$

But as the soot particles in question are very small (in the order of 1.0µm or less) it is quite natural that molecular slip will occur, resulting in a lower drag force than that from the above relation. For this reason the Cunningham's Correction Factor 'C*' is introduced in Drag Force to take into account molecular slip for very small soot particles in the range mentioned above. Therefore, considering Correction Factor which is greater than unity acts to decrease the resistance to particle motion, and the modified drag force becomes as follows. Drag force on a spherical particle may be determined by the Stokes law. By introducing Cunningham's slip correction factor for molecular slip we get the expression for drag force as

Drag force $F_d = \frac{3\pi\mu d_p (V_r - V_{gr})}{C}$

$$F_d = \frac{\{3\pi\mu d_p (V_r - V_{gr})\}}{C}$$

$$F_d = \frac{\left\{3\pi\mu d_p \left(\frac{dr}{dt} - V_{gr}\right)\right\}}{C^*} \text{------(vi)}$$

$$C^* = 1 + 2 \frac{\lambda}{d_p} (1.257 + 0.400e^{-0.55d_p/\lambda}) \text{ [W. Strauss, 1966(80)]}$$

$$\lambda = \frac{\mu}{0.499\rho u} \quad \& \quad \bar{u} = \sqrt{\frac{8R_u T}{\pi M}}$$

Where C* = Cunningham's Correction Factor
 ū = Mean molecular velocity of the particle
 μ= Dynamic viscosity of diesel engine exhaust

$(V_r - V_{gr}) =$ Relative radial velocity of particle

$V_r =$ Particle radial velocity $= \frac{dr}{dt}$

[Where r be any radial distance from the centre of the vortex]

$V_{gr} =$ Air stream radial velocity

Basically the static particle theory suggested that the critically sized particle (d_{50}) is smaller than the smallest particle, which is collected, and larger than the largest particle that penetrates the cyclone. Particles with diameter of d_{50} theoretically suspends in the outer vortex due to the force balance. Even though there is a d_{50} distribution in the outer space, only those d_{50} on the interface of inner vortex and outer vortex will characterize the electro-cyclone performance and represent the cut-point of the electro-cyclone. To solve the force balance differential equation (4), Barth made several assumptions:

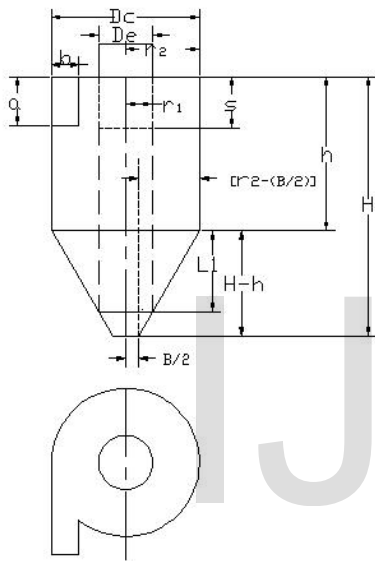

1. The particle radial velocity was assumed to be zero because of static status.

$$\text{Hence, } V_r = \frac{dr}{dt} = 0, \Rightarrow \frac{d^2r}{dt^2} = 0,$$

2. It was also assumed that exhaust gas uniformly leaked from the outer vortex to the inner vortex. So, the air inwards radial velocity was determined by the following equation.

$$V_{gr} = -\frac{Q}{\pi D_o Z_o} \quad [\text{Inward direction}]$$

Now the equation (vi) becomes

$$F_d = \frac{3\pi\mu d_p}{C^*} \left\{ -\left(\frac{-Q}{\pi D_o Z_o} \right) \right\}$$

$$F_d = \frac{3Q\mu d_p}{C^* D_o Z_o} \text{-----(vii)}$$

Therefore at the balance point the centrifugal force plus electrostatic force are equal to the drag force acting on the particle.^[11]

So we can write equation (i) as

$$F_c + F_e = F_d$$

$$\Rightarrow -\frac{\pi d_p^3 \rho_p}{6} \frac{R}{r^2} V_{in}^2 + q_{es} \frac{V}{r} = \frac{3Q\mu d_p}{C^* D_o Z_o}$$

Simplifying the above we get

$$\Rightarrow -(\pi\rho_p RV_{in}^2 CD_0 Z_0) d_p^3 + 6q_{es} rVCD_0 Z_0 = (18Qr^2 \mu) d_p$$

$$\Rightarrow (\pi\rho_p RV_{in}^2 CD_0 Z_0) d_p^3 + (18Qr^2 \mu) d_p - 6q_{es} rVCD_0 Z_0 = 0$$

Where z_0 is the vortex length ,also known as electro-cyclone effective length ^[14].

The maximum tangential velocity may be several times the average inlet gas velocity (Perry and Green,1984 [11])and normally found in between 1.5 to 2.5 times the inlet velocity.

Taking $V_t=1.5V_{in}$ and according to Stairmand model $Q = abV_{in}$, $V_{in} = \frac{Q}{ab}$

Putting $R = \frac{D_c}{2}$; $D_0 = \frac{D_c}{2}$; $r = \frac{D_c}{4}$; $Z_0 = 3D_c$, Where D_c is the diameter of electro-cyclone separator. ^[14,15,16]

Substituting the v_t and Q in terms of v_{in} and R, D_0 , r, Z_0 in terms of D_c the above equation becomes

$$\Rightarrow \left(\frac{3}{4} \pi D_c^3 \rho_p V_{in}^2 C\right) d_p^3 + \left(\frac{9}{8} \mu ab V_{in} D_c^2\right) d_p - \left(\frac{9}{4} q_{es} D_c^3 VC\right) = 0 \text{----- (iv)}$$

This is a cubic equation of d_p and it can be solved by Cardon’s method. Since the discriminate of the roots is ≥ 0 , therefore we may get one real value of d_p and other two imaginary values.

Neglecting the imaginary values we get d_{p50} .

Parameter taken for the above calculations are given in the tabular form:

Parameters	Values	References
Allowable pressure drop	<300 mbar,3000(pa) <400 mbar, 4000(pa)	Dementhon and Martin(1997) Luders <i>et al.</i> (1999)
Temperature	(100-500) degree celcius	Horiuchi <i>et al.</i> (1990)
Density of soot particle	(2000-1600) kg/m3	Muntean(1990)
Exhaust viscosity	2.97/10 ⁶ kg/ms	Suresh <i>et al.</i> (2000)
Exhaust density	(0.501-0.54) kg/m3	Suresh <i>et al.</i> (2000)
Volume flow rate	(0.02-0.40) m3/sec	Mayer <i>et al.</i> (1995)
Aerodynamic equivalent diameter [AED]	(1-10) micron	Dementhon Martin (1997)
Diesel particulate diameter	<=(0.1-1) micron, <1 mm	Khalil and Levendis (1992)

Theoretical Particle Collection Efficiency:

Particle collection efficiency, η is defined as the percentage of particles in number collected by the electro cyclone over the total number of particles entering the electro cyclone separator ^[18].

Lapple (1950) found a correlation between the collection efficiency and $\frac{D_{p50}}{D_p}$ which was shown by Theodore and Depaola (1980) to be:

$$\eta = \frac{1}{1 + \left(\frac{D_{p50}}{D_p}\right)^2} \text{----- (v)}$$

Where D_{p50} is calculated by equation (iv). Assuming $D_p = 0.1$ micron

RESULTS AND DISCUSSION:

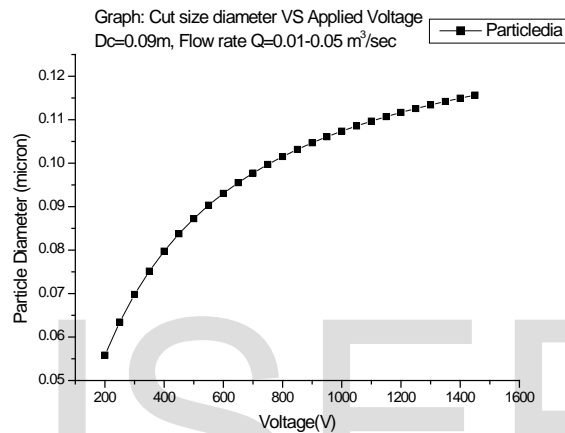

Figure-1

Figure: 1. shows that the soot particulate diameter (size) increases with the increase of applied voltage. From the relation (iv) we other parameter remain constant, due to increase in applied voltage arresting particle sizes will be larger. We know that larger size of particles will be charged due to increase in applied voltage between the two electrodes and as a whole, increase of arresting particle sizes with the increase of applied voltage in the electro-cyclone separator. This is why d_{50} also increase with the increase in voltage. Similar trends are observed with the theoretical work of Bo NI, Vance BERGERON, Satish Malik ,on bioaerosol collection by mini electro-cyclones[19].

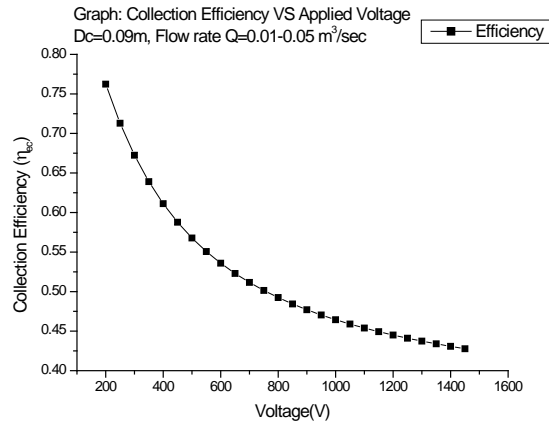

Figure-2

Figure: 2. shows that the electro-cyclone separator collection efficiency of smaller size soot particulate matter will increase at low applied voltage. This means that at higher voltage, large size of particle can be arrested. Due to increase of applied voltage, efficiency of arresting large size particle decrease. Maximum collection efficiency of large size particle is obtained at higher voltage.

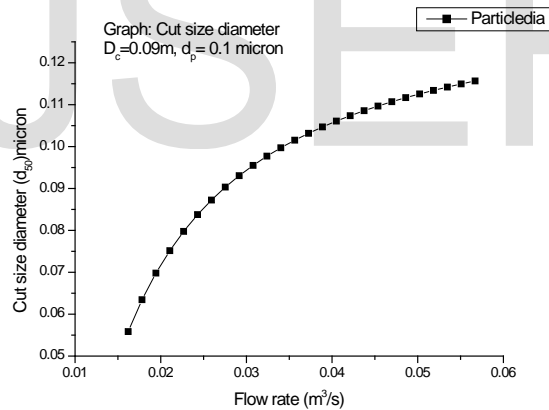

Figure-3

Figure 3: shows the variation of cut size diameter with flow rate. Theoretical model predicts that with increase in flow rate cut size diameter increases. The cut off diameter increases with the increasing of flow rate because particle residential time is becoming less and less important and not enough to enable the particles to migrate to electro-cyclone wall. In electro-cyclone collection efficiency is favoured by lower exhaust gas velocity. The increase of flow rate no longer results in the improvement of its collection efficiency. Lower flow rate means lower pressure drop and lower energy consumption. Therefore, there are good reasons to reduce flow rates in electro-cyclone. Graphical trends matches with the analysis of collection efficiency.

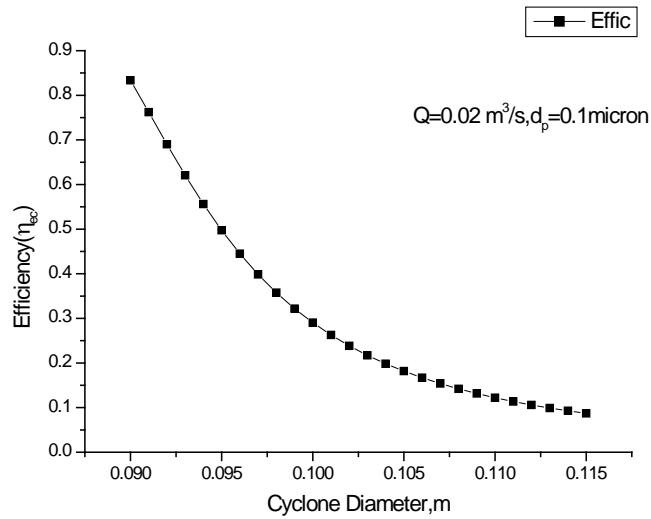

Figure-4

Figure 4: shows the variation of electro-cyclone efficiency with Cyclone Diameter. Theoretical model predicts that with the decrease of cyclone diameter the electro-cyclone efficiency increases. With the decrease of electro-cyclone diameter the electrostatic force on the particle increases due to decrease of separation distance between two electrodes and hence particulate collection efficiency also increases.

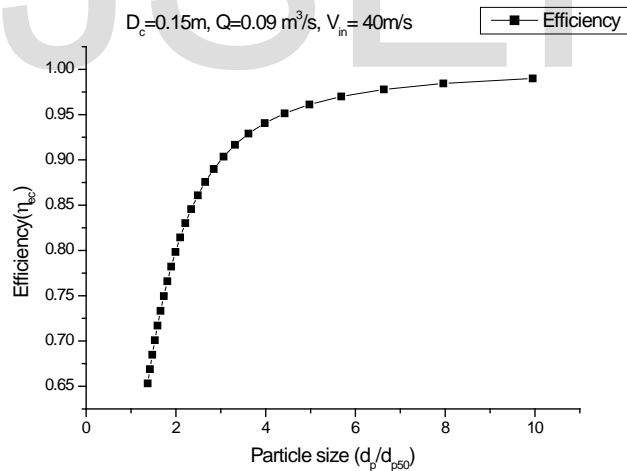

Figure-5

Figure 4: shows the variation of electro-cyclone efficiency with particle size. Theoretical model predicts that the electro-cyclone efficiency increases with the increase of normalized particle size ratio. Predicted results of the modified cut size diameter (d_{p50}) model presents the similar matching trends with that of the work of Lapple, 1951, [20] and experimental work of Wheeldon, 1987 [21] on a PFBC unit.

CONCLUSION:

- Analytical approach for collection efficiency of electro-cyclone separator as a Diesel particulate filter considering external applied electric field have been proposed.
- Electro cyclone separator studies as a Diesel Engine soot particulate emission arrester is presented.
- Graphical trend show good agreements with the other industries using electro-cyclone separator.
- Modified d_{p50} model shows good agreement with publishing works.
- Proposed analytical model of Electro-cyclone separator as a Diesel Particulate filter exhibits the same flow trends with existing experimental work.

NOTATION:

A: Inlet cross sectional area of electro-cyclone flow [m²]

a : Inlet height of the electro-cyclone [m]

b : Inlet width of the electro-cyclone [m]

D_c : Diameter of electro cyclone separator [m]

D_e : Outer diameter of the cyclone [m]

D: Diameter of the vortex finder [m]

D_d : Diameter of the dust exit [m]

D_0 : Inner vortex core diameter [m]

d_{p50} : Cut size diameter of the particle [μ m]

d_p : Diameter of soot particle [μ m]

F_c : Centrifugal force [N]

F_d : drag force acting on the particle [N]

F_e : Electrostatic force acting on the particle [N]

E : Electric field strength [Volt/m]

q_{es} : Charged induced on the particle [Culomb]

V : Voltage applied [Volt]

V_t : Tangential Velocity of exhaust Gas [m/sec]

V_r : Radial velocity of particle [m/sec]

V_{in} : Inlet Velocity of exhaust gas [m/sec]

V_{gr} : Air stream radial velocity [m/sec]

λ : Mean free path of the particle[m]

M : Mass of the particle

R : Radius of electro-cyclone well [m]

L_1 : Length of the cylindrical portion of the cyclone [m]

n : vortex exponent

T: exhaust gas temperature in K

N_θ : Number of particles remains in the outer vortex at an angle of turn θ

Q: volume flow rate [m³/sec]

r : Radius of electro-cyclone separator [m]

t : Temperature of the exhaust gas [$^{\circ}\text{C}$]
 ρ_e : Density of the exhaust gas [kg/m^3]
 ρ_p : Density of the particle [kg/m^3]
 η : Collection efficiency electro-cyclone separator
 μ : dynamic viscosity of the gas [$\text{kg}/\text{m}\cdot\text{sec}$]
 θ : Angle of turn in traversing the cyclone [rad]
 R_u : Universal gas constant, in N-m/kmolk
 Z_0 : Electro-cyclone effective length [m]

Reference:

1. DIESEL PARTICULATE MATTER SAMPLING METHODS Supplemental Report AEROSOL DYNAMICS, LABORATORY AND ON-ROAD STUDIES, Prepared by David B. Kittelson, Ph.D., Winthrop F. Watts, Jr., Ph.D. and Megan Arnold University of Minnesota Department of Mechanical Engineering Center for Diesel Research Minneapolis, MN July 31, 1998
2. ELECTROSTATIC CAPTURE AND AGGLOMERATION OF PARTICLES EMITTED BY DIESEL ENGINE, M. FARZANEH, MA. ALLAIRE, K. MARCEAU AND P. LACHANCE Universit  du Qu bec   Chicoutimi Chicoutimi, Qu bec, Canada, G7H 2B1
3. Mothes, H. and F. Loffer, "Prediction of particle removal in cyclone separators", Int.Chem. Eng. 28(2), pp. 231 – 240,1988.
4. Cooper, C.D., F.C.Alley., "Air pollution control : A design approach.", Waveland Press,Inc., Prospect Heights, IL, Illinois, 1994.
5. Iozia,D.L., D. Leith., " The Logistic equation and cyclone fractional efficiency.", Aerosol Science and Technology. 13(1).1990.
6. Swift,P., " Dust control in industry.", Steam Heating Engineering. 38.1969.
7. Koch,W.H. and Licht,W., "New design approach boosts cyclone efficiency.", November 7,1977, Chem. Eng., pp 80 – 88.
8. Wang, L., C.B. Parnell, et. al., "A study of Fractional Efficiency curves.", Agricultural Engineering International: the CIGR Journal of Scientific Research and Development. Manuscript BC 02 002. Vol. IV.June,2002.
9. Wheeldon, J.L., Burnard, G.K.," Performance of Cyclones in the off – Gas path of a Pressurised Fluidised Bed Combustor", Filtration & Separation, pp. 178 – 187, May/June1987.
10. Garde, S., Tilak, S., Subrahmanyam, J. P., Gajendra Babu, M.K. "Particulate Control of Diesel Engine Exhaust using a Low Cost Cyclonic Separator", XI National Conference Proceedings on I.C.Engine & Combustion, December 11-15, 1989, IIT Madras, India.
11. Jiwu Li, Weijian Cai, "Study of the cut diameter of solid-gas separation in cyclone with electrostatic excitation", Journal of Electrostatic 60 (2004) 15-23
12. Bo NI, Vance BERGERON, Satish MALIK, " Numerical and experimental studies on mini electro-cyclones for bioaerosol collection at individual level"

13. Jiwu Li, Weijian Cai "Theory and application of cyclone with impulse electrostatic excitation for cleaning molecular gas" *Journal of Electrostatics* 64 (2006) 254–258
14. Mukhopadhyay, N., Bose, P.K., Chakrabarti, R.K., "A New Theoretical Approach of Designing Cyclone Separator for Controlling Diesel Soot Particulate Emission", *SAE International (USA)/SP-2052*, 2006-01-1978 (2006).
15. Bose, P.K., Roy, K., Mukhopadhyay, N., Chakraborty, R.K., "An Improved Theoretical Modeling of Cyclone Separator as a Diesel Soot Particulate Emission Arrester", *International Journal of Automotive Technology (Korea)*, E2007166, (2008), in press.
16. Mukhopadhyay, N., Bose, P.K., Mitra, S., "Theoretical and experimental modeling of cyclone separator as a diesel soot particulate emission arrester with a continuous ceramic packed fiber filter placed at the end of the vortex finder tube", *AMSE, France*, 07313, 2B, (In press), 2009.
17. J. Li, et al., Experiment study of the performance of cyclone impulse electrostatic precipitation, *Acta Sci. Circumstantiae* (2) (2002) 39–41.
18. Kung-Yu Kuo and Chuen-Jinn Tsai., "On the Theory of Particle Cutoff Diameter and Collection Efficiency of Cyclones"
19. Bo NI, Vance BERGERON, Satish Malik., "Numerical and experimental studies on mini electro-cyclones for bioaerosol collection at individual level"
20. Lapple, C.E., "Processes Use Many Collection Types.", *Chemical Engineer*, vol.58, no. 5, pp. 144-151, May 1951.
21. Wheeldon, J.L., Burnard, G.K., "Performance of Cyclones in the off-Gas path of a Pressurised Fluidised Bed Combustor", *Filtration & Separation*, pp. 178 – 187, May/June 1987.